

भारतीय मानक

इस्पात के चूड़ीदार बंधकों की तकनीकी पूर्ति शर्तें

भाग 3 कार्बन स्टील एवं एलॉय स्टील के बने बंधकों के
यांत्रिक गुण धर्म — काबले, पेंच एवं स्टड्स

(चौथा पुनरीक्षण)

Indian Standard

**TECHNICAL SUPPLY CONDITIONS FOR
THREADED STEEL FASTENERS**

**PART 3 MECHANICAL PROPERTIES OF FASTENERS MADE OF CARBON
STEEL AND ALLOY STEEL — BOLTS, SCREWS AND STUDS**

(*Fourth Revision*)

ICS 21.060.10

© BIS 2002

BUREAU OF INDIAN STANDARDS
MANAK BHAVAN, 9 BAHADUR SHAH ZAFAR MARG
NEW DELHI 110002

Bolts, Nuts and Fasteners Accessories Sectional Committee, BP 33

NATIONAL FOREWORD

This Indian Standard (Fourth Revision) which is identical with ISO 898-1 : 1999 'Mechanical properties of fasteners made of carbon steel and alloy steel — Part 1 : Bolts, screws and studs' issued by the International Organization for Standardization (ISO) was adopted by the Bureau of Indian Standards on the recommendations of the Bolts, Nuts and Fasteners Accessories Sectional Committee and approval of the Basic and Production Engineering Division Council.

IS 1367 which covers the 'Technical supply conditions for threaded steel fasteners' was originally published in 1961 and first revised in 1967. In the late seventies, the second revision was taken up when the work of ISO/TC 2, 'Fasteners' taken into consideration of our national work on industrial fasteners. Accordingly, the Committee decided that IS 1367 should be brought out into several parts, each part covering a particular feature or property of the fasteners. Subsequently, the second revision of this standard was published in 1979. The third revision was published in 1991 by adoption of ISO 898-1 : 1988. This fourth revision has been prepared by adoption of latest edition of ISO 898-1 published in 1999.

The text of ISO Standard has been approved as suitable for publication as Indian Standard without deviation. Certain terminology and conventions are, however, not identical to those used in the Indian Standards. Attention is drawn especially to the following:

- a) Wherever the words 'International Standard' appear referring to this standard, they should be read as 'Indian Standard'.
- b) Comma (,) has been used as a decimal marker while in Indian Standards, the current practice is to use a point (.) as the decimal marker.

In this adopted standard, reference appears to certain International Standards for which Indian Standards also exist. The corresponding Indian Standards which are to be substituted in their place are listed below along with their degree of equivalence for the editions indicated:

<i>International Standard</i>	<i>Corresponding Indian Standard</i>	<i>Degree of Equivalence</i>
ISO 68-1 : 1998	IS 4218 (Part 1) : 1999 ISO General purpose metric screw thread: Part 1 Basic profile (<i>second revision</i>)	Identical
ISO 83 : 1976	IS 1499 : 1977 Method for Charpy impact test (U-notch) for metals (<i>first revision</i>)	Technically equivalent
ISO 261 : 1998	IS 4218 (Part 2) : 2001 ISO General purpose metric screw threads: Part 2 General Plan (<i>second revision</i>)	Identical
ISO 262 : 1998	IS 4218 (Part 4) : 2001 ISO General purpose metric screw threads: Part 4 Selected sizes for screws, bolts and nuts (<i>second revision</i>)	do
ISO 724 : 1978 ¹⁾	IS 4218 (Part 3) : 1999 ISO General purpose metric screw threads: Part 3 Basic dimensions (<i>second revision</i>)	do
ISO 898-2 : 1992	IS 1367 (Part 6) : 1994 Technical supply conditions for threaded steel fasteners: Part 6 Mechanical properties and test methods for nuts with specified proof loads (<i>third revision</i>)	do

¹⁾ Since revised in 1993.

<i>International Standard</i>	<i>Corresponding Indian Standard</i>	<i>Degree of Equivalence</i>
ISO 898-5 : 1998	IS 1367 (Part 5) : 2002 Technical supply conditions for threaded steel fasteners: Part 5 Mechanical properties and test methods for set screws and similar threaded fasteners not under tensile stresses (<i>third revision</i>)	Identical
ISO 898-7 : 1992	IS 1367 (Part 20) : 1996 Industrial fasteners — Threaded steel fasteners — Technical supply conditions — Mechanical properties: Part 20 Torsional test and minimum torques for bolts and screws with nominal diameters 1 mm to 10 mm	do
ISO 965-1 : 1998	IS 14962 (Part 1) : 2001 ISO General purpose metric screw threads — Tolerances: Part 1 Principles and basic data	do
ISO 965-2 : 1998	IS 14962 (Part 2) : 2001 ISO General purpose metric screw threads — Tolerances: Part 2 Limits of sizes for general purpose external and internal screw threads — Medium quality	do
ISO 3269 : ¹⁾	IS 1367 (Part 17) : 1996 ²⁾ Industrial fasteners — Threaded steel fasteners — Technical supply conditions: Part 17 Inspection, sampling and acceptance procedure (<i>third revision</i>)	do
ISO 4042 : 1999	IS 1367 (Part 11) : 2002 Technical supply conditions for threaded steel fasteners: Part 11 Electroplated coatings (<i>third revision</i>)	do
ISO 4759-1 : ³⁾	IS 1367 (Part 2) : 2002 Technical supply conditions for threaded steel fasteners: Part 2 Product grades and tolerances (<i>third revision</i>)	do
ISO 6157-1 : 1988	IS 1367 (Part 9/Sec 1) : 1993 Technical supply conditions for threaded steel fasteners : Part 9 Surface discontinuities, Section 1 Bolts, screws and studs for general applications (<i>third revision</i>)	do
ISO 6157-2 : 1995	IS 1367 (Part 10) : 2002 Technical supply conditions for threaded steel fasteners : Part 10 Surface discontinuities — Nuts (<i>third revision</i>)	do
ISO 6157-3 : 1988	IS 1367 (Part 9/Sec 2) : 1993 Technical supply conditions for threaded steel fasteners : Part 9 Surface discontinuities, Section 2 Bolts, screws and studs for special applications (<i>third revision</i>)	do
ISO 6506 : 1981	IS 1500 : 1983 Method for Brinell hardness test for metallic materials (<i>second revision</i>)	Technically equivalent

¹⁾ To be published (Revision of ISO 3269 : 1988).

²⁾ Identical with ISO 3269 : 1988.

³⁾ Since published in 2000.

<i>International Standard</i>	<i>Corresponding Indian Standard</i>	<i>Degree of Equivalence</i>
ISO 6507-1 : 1997	IS 1501 (Part 1) : 1984 ¹⁾ Method for Vickers hardness test for metallic materials : Part 1 HV 5 to HV 100 (<i>second revision</i>)	Technically equivalent
ISO 6508 : 1986	IS 1586 : 2000 Method for Rockwell hardness test for metallic materials (scales A, B, C, D, E, F, G, H, K, 15 N, 30 N, 45 N, 15 T, 30 T and 45 T) (<i>third revision</i>)	do
ISO 6892 : 1998	IS 1608 : 1995 Mechanical testing of metals — Tensile testing (<i>second revision</i>)	Related
ISO 8992 : 1986	IS 1367 (Part 1) : 2002 Technical supply conditions for threaded steel fasteners: Part 1 Introduction and general information (<i>third revision</i>)	Identical

In reporting the results of a test or analysis made in accordance with this standard, if the final value, observed or calculated, is to be rounded off, it shall be done in accordance with IS 2 : 1960 'Rules for rounding off numerical values (*revised*)'.

¹⁾ Based on ISO 6507 : 1982 which has been revised in 1997.

Indian Standard

TECHNICAL SUPPLY CONDITIONS FOR THREADED STEEL FASTENERS

PART 3 MECHANICAL PROPERTIES OF FASTENERS MADE OF CARBON STEEL AND ALLOY STEEL — BOLTS, SCREWS AND STUDS

(*Fourth Revision*)

1 Scope

This part of ISO 898 specifies the mechanical properties of bolts, screws and studs made of carbon steel and alloy steel when tested at an ambient temperature range of 10 °C to 35 °C.

Products conforming to the requirements of this part of ISO 898 are evaluated only in the ambient temperature range and may not retain the specified mechanical and physical properties at higher and lower temperatures. Attention is drawn to annex A which provides examples of lower yield stress and stress at 0,2 % non-proportional elongation at elevated temperatures.

At temperatures lower than the ambient temperature range, a significant change in the properties, particularly impact strength, may occur. When fasteners are to be used above or below the ambient temperature range it is the responsibility of the user to ensure that the mechanical and physical properties are suitable for his particular service conditions.

Certain fasteners may not fulfill the tensile or torsional requirements of this part of ISO 898 because of the geometry of the head which reduces the shear area in the head as compared to the stress area in the thread such as countersunk, raised countersunk and cheese heads (see clause 6).

This part of ISO 898 applies to bolts, screws and studs

- with coarse pitch thread M1,6 to M39, and fine pitch thread M8 × 1 to M39 × 3;
- with triangular ISO thread in accordance with ISO 68-1;
- with diameter/pitch combinations in accordance with ISO 261 and ISO 262;
- with thread tolerance in accordance with ISO 965-1 and ISO 965-2;
- made of carbon steel or alloy steel.

It does not apply to set screws and similar threaded fasteners not under tensile stresses (see ISO 898-5).

It does not specify requirements for such properties as

- weldability;
- corrosion-resistance;
- ability to withstand temperatures above + 300 °C (+ 250 °C for 10.9) or below – 50 °C;
- resistance to shear stress;
- fatigue resistance.

NOTE The designation system of this part of ISO 898 may be used for sizes outside the limits laid down in this clause (e.g. $d > 39$ mm), provided that all mechanical requirements of the property classes are met.

2 Normative references

The following standards contain provisions which, through reference in this text, constitute provisions of this part of ISO 898. At the time of publication, the editions indicated were valid. All standards are subject to revision, and parties to agreements based on this part of ISO 898 are encouraged to investigate the possibility of applying the most recent editions of the standards indicated below. Members of IEC and ISO maintain registers of currently valid International Standards.

ISO 68-1:1998, *ISO general purpose screw threads – Basic profile – Part 1: Metric screw threads.*

ISO 83:1976, *Steel – Charpy impact test (U-notch).*

ISO 261:1998, *ISO general purpose metric screw threads – General plan.*

ISO 262:1998, *ISO general purpose metric screw threads – Selected sizes for screws, bolts and nuts.*

ISO 273:1979, *Fasteners – Clearance holes for bolts and screws.*

ISO 724:1978, *ISO general purpose metric screw threads – Basic dimensions.*

ISO 898-2:1992, *Mechanical properties of fasteners made of carbon steel and alloy steel – Part 2: Nuts with specified proof load values – Coarse thread.*

ISO 898-5:1998, *Mechanical properties of fasteners made of carbon steel and alloy steel – Part 5: Set screws and similar threaded fasteners not under tensile stresses.*

ISO 898-7:1992, *Mechanical properties of fasteners made of carbon steel and alloy steel – Part 7: Torsional test and minimum torques for bolts and screws with nominal diameters 1 mm to 10 mm.*

ISO 965-1:1998, *ISO general purpose metric screw threads – Tolerances – Part 1: Principles and basic data.*

ISO 965-2:1998, *ISO general purpose metric screw threads – Tolerances – Part 2: Limits of sizes for general purpose external and internal screw threads – Medium quality.*

ISO 6157-1:1988, *Fasteners – Surface discontinuities – Part 1: Bolts, screws and studs for general requirements.*

ISO 6157-3:1988, *Fasteners – Surface discontinuities – Part 3: Bolts, screws and studs for special requirements.*

ISO 6506:1981, *Metallic materials – Hardness test – Brinell test.*

ISO 6507-1:1997, *Metallic material – Hardness test – Vickers test – Part 1: Test method.*

ISO 6508:1986, *Metallic materials – Hardness test – Rockwell test (scales A - B - C - D - E - F - G - H - K).*

ISO 6892:1998, *Metallic materials – Tensile testing at ambient temperature.*

3 Designation system

The designation system for property classes of bolts, screws and studs is shown in table 1. The abscissae show the nominal tensile strength values, R_m , in newtons per square millimetre, while the ordinates show those of the minimum elongation after fracture, A_{min} , as a percentage.

The property class symbol consists of two figures:

- the first figure indicates 1/100 of the nominal tensile strength in newtons per square millimetre (see 5.1 in table 3);
- the second figure indicates 10 times the ratio between lower yield stress R_{eL} (or stress at 0,2 % non-proportional elongation $R_{p0,2}$) and nominal tensile strength $R_{m, nom}$ (yield stress ratio).

The multiplication of these two figures will give 1/10 of the yield stress in newtons per square millimetre.

The minimum lower yield stress $R_{eL, \min.}$ (or minimum stress at 0,2 % non-proportional elongation $R_{p0,2, \min.}$) and minimum tensile strength $R_{m, \min.}$ are equal to or greater than the nominal values (see table 3).

4 Materials

Table 2 specifies steels and tempering temperatures for the different property classes of bolts, screws and studs.

The chemical composition shall be assessed in accordance with the relevant ISO standards.

5 Mechanical and physical properties

When tested by the methods described in clause 8, the bolts, screws and studs shall, at ambient temperature, have the mechanical and physical properties set out in table 3.

Table 1 — System of coordinates

Nominal tensile strength $R_{m, nom}$ N/mm ²	300	400	500	600	700	800	900	1 000	1 200	1 400
	7									
8										
9				6.8					12.9	
10								10.9		
12				5.8			9.8 ^a			
14						8.8				
16			4.8							
18										
20										
22				5.6						
25			4.6							
30		3.6								
30										
Relationship between yield stress and tensile strength										
Second figure of symbol								.6	.8	.9
$\frac{\text{Lower yield stress } R_{eL}^b}{\text{Nominal tensile strength } R_{m, nom}} \times 100 \%$								60	80	90
or										
$\frac{\text{Stress at 0,2 % non-proportional elongation } R_{p0,2}^b}{\text{Nominal tensile strength } R_{m, nom}} \times 100 \%$										
NOTE Although a great number of property classes are specified in this part of ISO 898, this does not mean that all classes are appropriate for all items. Further guidance for application of the specific property classes is given in the relevant product standards. For non-standard items, it is advisable to follow as closely as possible the choice already made for similar standard items.										
a Applies only to thread diameter $d \leq 16$ mm.										
b Nominal values according to table 3 apply.										

Table 2 — Steels

Property class	Material and treatment	Chemical composition limits (check analysis) % (m/m)				Tempering temperature °C min.	
		C		P	S		B ^a max.
		min.	max.	max.	max.		
3.6 ^b	Carbon steel	—	0,20	0,05	0,06	0,003	—
4.6 ^b		—	0,55	0,05	0,06	0,003	—
4.8 ^b							
5.6		0,13	0,55	0,05	0,06	0,003	—
5.8 ^b		—	0,55	0,05	0,06		
6.8 ^b							
8.8 ^c	Carbon steel with additives (e.g. B, Mn or Cr) quenched and tempered	0,15 ^d	0,40	0,035	0,035	0,003	425
	Carbon steel quenched and tempered	0,25	0,55	0,035	0,035		
9.8	Carbon steel with additives (e.g. B, Mn or Cr) quenched and tempered	0,15 ^d	0,35	0,035	0,035	0,003	425
	Carbon steel quenched and tempered	0,25	0,55	0,035	0,035		
10.9 ^{e f}	Carbon steel with additives (e.g. B, Mn or Cr) quenched and tempered	0,15 ^d	0,35	0,035	0,035	0,003	340
10.9 ^f	Carbon steel quenched and tempered	0,25	0,55	0,035	0,035	0,003	425
	Carbon steel with additives (e.g. B, Mn or Cr) quenched and tempered	0,20 ^d	0,55	0,035	0,035		
	Alloy steel quenched and tempered ^g	0,20	0,55	0,035	0,035		
12.9 ^{f h i}	Alloy steel quenched and tempered ^g	0,28	0,50	0,035	0,035	0,003	380

^a Boron content can reach 0,005 % provided that non-effective boron is controlled by addition of titanium and/or aluminium.

^b Free cutting steel is allowed for these property classes with the following maximum sulfur, phosphorus and lead contents: sulfur 0,34 %; phosphorus 0,11 %; lead 0,35 %.

^c For nominal diameters above 20 mm the steels specified for property classe 10.9 may be necessary in order to achieve sufficient hardenability.

^d In case of plain carbon boron steel with a carbon content below 0,25 % (ladle analysis), the minimum manganese content shall be 0,6 % for property class 8.8 and 0,7 % for 9.8, 10.9 and 10.9.

^e Products shall be additionally identified by underlining the symbol of the property class (see clause 9). All properties of 10.9 as specified in table 3 shall be met by 10.9, however, its lower tempering temperature gives it different stress relaxation characteristics at elevated temperatures (see annex A).

^f For the materials of these property classes, it is intended that there should be a sufficient hardenability to ensure a structure consisting of approximately 90 % martensite in the core of the threaded sections for the fasteners in the "as-hardened" condition before tempering.

^g This alloy steel shall contain at least one of the following elements in the minimum quantity given: chromium 0,30 %, nickel 0,30 %, molybdenum 0,20 %, vanadium 0,10 %. Where elements are specified in combinations of two, three or four and have alloy contents less than those given above, the limit value to be applied for class determination is 70 % of the sum of the individual limit values shown above for the two, three or four elements concerned.

^h A metallographically detectable white phosphorous enriched layer is not permitted for property class 12.9 on surfaces subjected to tensile stress.

ⁱ The chemical composition and tempering temperature are under investigation.

Table 3 — Mechanical and physical properties of bolts, screws and studs

Sub-clause number	Mechanical and physical property	Property class												
		3.6	4.6	4.8	5.6	5.8	6.8	8.8 ^a		9.8 ^b	10.9	12.9		
								<i>d</i> ≤ 16 ^c mm	<i>d</i> > 16 ^c mm					
5.1	Nominal tensile strength, $R_{m, nom}$ N/mm ²	300	400		500		600	800	800	900	1 000	1 200		
5.2	Minimum tensile strength, $R_{m, min}^{d e}$ N/mm ²	330	400	420	500	520	600	800	830	900	1 040	1 220		
5.3	Vickers hardness, HV $F \geq 98$ N	min.	95	120	130	155	160	190	250	255	290	320	385	
		max.	220 ^f					250	320	335	360	380	435	
5.4	Brinell hardness, HB $F = 30 D^2$	min.	90	114	124	147	152	181	238	242	276	304	366	
		max.	209 ^f					238	304	318	342	361	414	
5.5	Rockwell hardness, HR	min.	HRB	52	67	71	79	82	89	—	—	—	—	
			HRC	—	—	—	—	—	—	22	23	28	32	39
		max.	HRB	95,0 ^f					99,5	—	—	—	—	—
			HRC	—					—	32	34	37	39	44
5.6	Surface hardness, HV 0,3	max.	g											
5.7	Lower yield stress R_{eL}^h , N/mm ²	nom.	180	240	320	300	400	480	—	—	—	—		
		min.	190	240	340	300	420	480	—	—	—	—		
5.8	Stress at 0,2 % non-proportional elongation $R_{p0,2}^i$, N/mm ²	nom.	—					—	640	640	720	900	1 080	
		min.	—					—	640	660	720	940	1 100	
5.9	Stress under proof load, S_p N/mm ²	S_p/R_{eL} or $S_p/R_{p0,2}$	0,94	0,94	0,91	0,93	0,90	0,92	0,91	0,91	0,90	0,88	0,88	
		N/mm ²	180	225	310	280	380	440	580	600	650	830	970	
5.10	Breaking torque, M_B Nm min.	—							See ISO 898-7					
5.11	Percent elongation after fracture, A min.	25	22	—	20	—	—	12	12	10	9	8		
5.12	Reduction area after fracture, Z % min.	—							52	48	48	44		
5.13	Strength under wedge loading ^g	The values for full size bolts and screws (no studs) shall not be smaller than the minimum values for tensile strength shown in 5.2												
5.14	Impact strength, KU J min.	—			25	—		30	30	25	20	15		
5.15	Head soundness	No fracture												
5.16	Minimum height of non-decarburized thread zone, E	—							$\frac{1}{2} H_1$		$\frac{2}{3} H_1$	$\frac{3}{4} H_1$		
	Maximum depth of complete decarburization, G mm	—							0,015					
5.17	Hardness after retempering	—							Reduction of hardness 20 HV maximum					
5.18	Surface integrity	In accordance with ISO 6157-1 or ISO 6157-3 as appropriate												

a For bolts of property class 8.8 in diameters $d \leq 16$ mm, there is an increased risk of nut stripping in the case of inadvertent over-tightening inducing a load in excess of proof load. Reference to ISO 898-2 is recommended.

b Applies only to nominal thread diameters $d \leq 16$ mm.

c For structural bolting the limit is 12 mm.

d Minimum tensile properties apply to products of nominal length $l \geq 2,5 d$. Minimum hardness applies to products of length $l < 2,5 d$ and other products which cannot be tensile-tested (e.g. due to head configuration).

e When testing full-size bolts, screws and studs, the tensile loads, which are to be applied for the calculation of R_m , shall meet the values given in tables 6 and 8.

f A hardness reading taken at the end of bolts, screws and studs shall be 250 HV, 238 HB or 99,5 HRB maximum.

g Surface hardness shall not be more than 30 Vickers points above the measured core hardness on the product when readings of both surface and core are carried out at HV 0,3. For property class 10.9, any increase in hardness at the surface which indicates that the surface hardness exceeds 390 HV is not acceptable.

h In cases where the lower yield stress R_{eL} cannot be determined, it is permissible to measure the stress at 0,2 % non-proportional elongation $R_{p0,2}$. For the property classes 4.8, 5.8 and 6.8 the values for R_{eL} are given for calculation purposes only, they are not test values.

i The yield stress ratio according to the designation of the property class and the minimum stress at 0,2 % non-proportional elongation $R_{p0,2}$ apply to machined test specimens. These values if received from tests of full size bolts and screws will vary because of processing method and size effects.

6 Mechanical and physical properties to be determined

Two test programmes, A and B, for mechanical and physical properties of bolts, screws and studs, using the methods described in clause 8, are set out in table 5. Regardless of the choice of test programme, all requirements of table 3 shall be met.

The application of programme B is always desirable, but is mandatory for products with ultimate tensile loads less than 500 kN if the application of programme A is not explicitly agreed.

Programme A is suitable for machined test pieces and for bolts with a shank area less than the stress area.

Table 4 — Key to test programmes (see table 5)

Size	Bolts and screws with thread diameter $d \leq 3$ mm or length $l < 2,5 d^a$	Bolts and screws with thread diameter $d > 3$ mm and length $l \geq 2,5 d$
Test decisive for acceptance	○	●
^a Also bolts and screws with special head or shank configurations which are weaker than the threaded section.		

Table 5 — Test programmes A and B for acceptance purposes
(These procedures apply to mechanical but not chemical properties)

Test group	Property		Test programme A				Test programme B			
			Test method		Property class		Test method		Property class	
					3.6, 4.6	8.8, 9.8			3.6, 4.6	8.8, 9.8
				5.6	10.9			4.8, 5.6	10.9	
						5.8, 6.8			12.9	12.9
I	5.2	Minimum tensile strength, $R_{m, min}$	8.1	Tensile test	●	●	8.2	Tensile test ^a	●	●
	5.3 and 5.4 and 5.5	Minimum hardness ^b	8.4	Hardness test ^c	○	○	8.4	Hardness test ^c	○	○
		Maximum hardness			●	●			●	●
	5.6	Maximum surface hardness			○	○			○	○
					●			●	●	
II	5.7	Minimum lower yield stress $R_{eL, min}$ ^d	8.1	Tensile test	●					
	5.8	Stress at 0,2 % non-proportional elongation, $R_{p0,2}$ ^d	8.1	Tensile test		●				
	5.9	Stress under proof load, S_p					8.5	Proof load test	●	●
	5.10	Breaking torque, M_B					8.3	Torsional test ^e		○
III	5.11	Minimum percent elongation after fracture, A_{min} ^d	8.1	Tensile test	●	●				
	5.12	Minimum reduction of area after fracture Z_{min}	8.1	Tensile test		●				
	5.13	Strength under wedge loading ^f					8.6	Wedge loading test ^a	●	●
IV	5.14	Minimum impact strength, KU	8.7	Impact test ^g	● ^h	●				
	5.15	Head soundness ⁱ					8.8	Head soundness test	○	○
V	5.16	Maximum decarburized zone	8.9	Decarburization test		●	8.9	Decarburization test		●
	5.17	Hardness after retempering	8.10	Retempering test ^j		●	8.10	Retempering test ^j		●
	5.18	Surface integrity	8.11	Surface discontinuity inspection	●	●	8.11	Surface discontinuity inspection	●	●
				○	○			○	○	

- a If the wedge loading test is satisfactory, the axial tensile test is not required.
- b Minimum hardness applies only to products of nominal length $l < 2,5d$ and other products which cannot be tensile tested or torsional tested (e.g. due to head configuration).
- c Hardness may be Vickers, Brinell or Rockwell. In case of doubt, the Vickers hardness test is decisive for acceptance.
- d Only for bolts or screws with length $l \geq 6d$.
- e Only if bolts or screws cannot be tensile tested.
- f Special head bolts and screws with configurations which are weaker than the threaded section are excluded from wedge tensile testing requirements.
- g Only for bolts, screws and studs with thread diameters $d \geq 16$ mm and only if required by the purchaser.
- h Only property class 5.6.
- i Only for bolts and screws with thread diameters $d \leq 10$ mm and lengths too short to permit wedge load testing
- j Test not mandatory, to be applied as a referee test in the case of dispute only.

7 Minimum ultimate tensile loads and proof loads

See tables 6, 7, 8 and 9.

Table 6 — Minimum ultimate tensile loads – ISO metric coarse pitch thread

Thread ^a (d)	Nominal stress area $A_{s, nom}$ ^b mm ²	Property class									
		3.6	4.6	4.8	5.6	5.8	6.8	8.8	9.8•	10.9	12.9
		Minimum ultimate tensile load ($A_{s, nom} \times R_{m, min}$), N									
M3	5,03	1 660	2 010	2 110	2 510	2 620	3 020	4 020	4 530	5 230	6 140
M3,5	6,78	2 240	2 710	2 850	3 390	3 530	4 070	5 420	6 100	7 050	8 270
M4	8,78	2 900	3 510	3 690	4 390	4 570	5 270	7 020	7 900	9 130	10 700
M5	14,2	4 690	5 680	5 960	7 100	7 380	8 520	11 350	12 800	14 800	17 300
M6	20,1	6 630	8 040	8 440	10 000	10 400	12 100	16 100	18 100	20 900	24 500
M7	28,9	9 540	11 600	12 100	14 400	15 000	17 300	23 100	26 000	30 100	35 300
M8	36,6	12 100	14 600	15 400	18 300	19 000	22 000	29 200	32 900	38 100	44 600
M10	58	19 100	23 200	24 400	29 000	30 200	34 800	46 400	52 200	60 300	70 800
M12	84,3	27 800	33 700	35 400	42 200	43 800	50 600	67 400 ^c	75 900	87 700	103 000
M14	115	38 000	46 000	48 300	57 500	59 800	69 000	92 000 ^c	104 000	120 000	140 000
M16	157	51 800	62 800	65 900	78 500	81 600	94 000	125 000 ^c	141 000	163 000	192 000
M18	192	63 400	76 800	80 600	96 000	99 800	115 000	159 000	—	200 000	234 000
M20	245	80 800	98 000	103 000	122 000	127 000	147 000	203 000	—	255 000	299 000
M22	303	100 000	121 000	127 000	152 000	158 000	182 000	252 000	—	315 000	370 000
M24	353	116 000	141 000	148 000	176 000	184 000	212 000	293 000	—	367 000	431 000
M27	459	152 000	184 000	193 000	230 000	239 000	275 000	381 000	—	477 000	560 000
M30	561	185 000	224 000	236 000	280 000	292 000	337 000	466 000	—	583 000	684 000
M33	694	229 000	278 000	292 000	347 000	361 000	416 000	576 000	—	722 000	847 000
M36	817	270 000	327 000	343 000	408 000	425 000	490 000	678 000	—	850 000	997 000
M39	976	322 000	390 000	410 000	488 000	508 000	586 000	810 000	—	1 020 000	1 200 000

^a Where no thread pitch is indicated in a thread designation, coarse pitch is specified. This is given in ISO 261 and ISO 262.

^b To calculate A_s see 8.2.

^c For structural bolting 70 000 N, 95 500 N and 130 000 N, respectively.

Table 7 — Proof loads – ISO metric coarse pitch thread

Thread ^a (d)	Nominal stress area $A_{s, nom}$ ^b mm ²	Property class									
		3.6	4.6	4.8	5.6	5.8	6.8	8.8	9.8	10.9	12.9
		Proof load ($A_{s, nom} \times S_p$), N									
M3	5,03	910	1 130	1 560	1 410	1 910	2 210	2 920	3 270	4 180	4 880
M3,5	6,78	1 220	1 530	2 100	1 900	2 580	2 980	3 940	4 410	5 630	6 580
M4	8,78	1 580	1 980	2 720	2 460	3 340	3 860	5 100	5 710	7 290	8 520
M5	14,2	2 560	3 200	4 400	3 980	5 400	6 250	8 230	9 230	11 800	13 800
M6	20,1	3 620	4 520	6 230	5 630	7 640	8 840	11 600	13 100	16 700	19 500
M7	28,9	5 200	6 500	8 960	8 090	11 000	12 700	16 800	18 800	24 000	28 000
M8	36,6	6 590	8 240	11 400	10 200	13 900	16 100	21 200	23 800	30 400	35 500
M10	58	10 400	13 000	18 000	16 200	22 000	25 500	33 700	37 700	48 100	56 300
M12	84,3	15 200	19 000	26 100	23 600	32 000	37 100	48 900 ^c	54 800	70 000	81 800
M14	115	20 700	25 900	35 600	32 200	43 700	50 600	66 700 ^c	74 800	95 500	112 000
M16	157	28 300	35 300	48 700	44 000	59 700	69 100	91 000 ^c	102 000	130 000	152 000
M18	192	34 600	43 200	59 500	53 800	73 000	84 500	115 000	—	159 000	186 000
M20	245	44 100	55 100	76 000	68 600	93 100	108 000	147 000	—	203 000	238 000
M22	303	54 500	68 200	93 900	84 800	115 000	133 000	182 000	—	252 000	294 000
M24	353	63 500	79 400	109 000	98 800	134 000	155 000	212 000	—	293 000	342 000
M27	459	82 600	103 000	142 000	128 000	174 000	202 000	275 000	—	381 000	445 000
M30	561	101 000	126 000	174 000	157 000	213 000	247 000	337 000	—	466 000	544 000
M33	694	125 000	156 000	215 000	194 000	264 000	305 000	416 000	—	576 000	673 000
M36	817	147 000	184 000	253 000	229 000	310 000	359 000	490 000	—	678 000	792 000
M39	976	176 000	220 000	303 000	273 000	371 000	429 000	586 000	—	810 000	947 000

^a Where no thread pitch is indicated in a thread designation, coarse pitch is specified. This is given in ISO 261 and ISO 262.

^b To calculate A_s see 8.2.

^c For structural bolting 50 700 N, 68 800 N and 94 500 N, respectively.

Table 8 — Minimum ultimate tensile loads – ISO metric fine pitch thread

Thread ($d \times P^a$)	Nominal stress area $A_{s, \text{nom}}^b$ mm ²	Property class									
		3.6	4.6	4.8	5.6	5.8	6.8	8.8	9.8	10.9	12.9
		Minimum ultimate tensile load ($A_{s, \text{nom}} \times R_{m, \text{min}}$), N									
M8×1	39,2	12 900	15 700	16 500	19 600	20 400	23 500	31 360	35 300	40 800	47 800
M10×1	64,5	21 300	25 800	27 100	32 300	33 500	38 700	51 600	58 100	67 100	78 700
M10×1,25	61,2	20 200	24 500	25 700	30 600	31 800	36 700	49 000	55 100	63 600	74 700
M12×1,25	92,1	30 400	36 800	38 700	46 100	47 900	55 300	73 700	82 900	95 800	112 400
M12×1,5	88,1	29 100	35 200	37 000	44 100	45 800	52 900	70 500	79 300	91 600	107 500
M14×1,5	125	41 200	50 000	52 500	62 500	65 000	75 000	100 000	112 000	130 000	152 000
M16×1,5	167	55 100	66 800	70 100	83 500	86 800	100 000	134 000	150 000	174 000	204 000
M18×1,5	216	71 300	86 400	90 700	108 000	112 000	130 000	179 000	—	225 000	264 000
M20×1,5	272	89 800	109 000	114 000	136 000	141 000	163 000	226 000	—	283 000	332 000
M22×1,5	333	110 000	133 000	140 000	166 000	173 000	200 000	276 000	—	346 000	406 000
M24×2	384	127 000	154 000	161 000	192 000	200 000	230 000	319 000	—	399 000	469 000
M27×2	496	164 000	198 000	208 000	248 000	258 000	298 000	412 000	—	516 000	605 000
M30×2	621	205 000	248 000	261 000	310 000	323 000	373 000	515 000	—	646 000	758 000
M33×2	761	251 000	304 000	320 000	380 000	396 000	457 000	632 000	—	791 000	928 000
M36×3	865	285 000	346 000	363 000	432 000	450 000	519 000	718 000	—	900 000	1 055 000
M39×3	1 030	340 000	412 000	433 000	515 000	536 000	618 000	855 000	—	1 070 000	1 260 000

^a P is the pitch of the thread.

^b To calculate A_s see 8.2.

Table 9 — Proof loads – ISO metric fine pitch thread

Thread ($d \times p^a$)	Nominal stress area $A_{s, \text{nom}}^b$ mm ²	Property class									
		3.6	4.6	4.8	5.6	5.8	6.8	8.8	9.8	10.9	12.9
		Proof load ($A_{s, \text{nom}} \times S_p$), N									
M8×1	39,2	7 060	8 820	12 200	11 000	14 900	17 200	22 700	25 500	32 500	38 000
M10×1	64,5	11 600	14 500	20 000	18 100	24 500	28 400	37 400	41 900	53 500	62 700
M10×1,25	61,2	11 000	13 800	19 000	17 100	23 300	26 900	35 500	39 800	50 800	59 400
M12×1,25	92,1	16 600	20 700	28 600	25 800	35 000	40 500	53 400	59 900	76 400	89 300
M12×1,5	88,1	15 900	19 800	27 300	24 700	33 500	38 800	51 100	57 300	73 100	85 500
M14×1,5	125	22 500	28 100	38 800	35 000	47 500	55 000	72 500	81 200	104 000	121 000
M16×1,5	167	30 100	37 600	51 800	46 800	63 500	73 500	96 900	109 000	139 000	162 000
M18×1,5	216	38 900	48 600	67 000	60 500	82 100	95 000	130 000	—	179 000	210 000
M20×1,5	272	49 000	61 200	84 300	76 200	103 000	120 000	163 000	—	226 000	264 000
M22×1,5	333	59 900	74 900	103 000	93 200	126 000	146 000	200 000	—	276 000	323 000
M24×2	384	69 100	86 400	119 000	108 000	146 000	169 000	230 000	—	319 000	372 000
M27×2	496	89 300	112 000	154 000	139 000	188 000	218 000	298 000	—	412 000	481 000
M30×2	621	112 000	140 000	192 000	174 000	236 000	273 000	373 000	—	515 000	602 000
M33×2	761	137 000	171 000	236 000	213 000	289 000	335 000	457 000	—	632 000	738 000
M36×3	865	156 000	195 000	268 000	242 000	329 000	381 000	519 000	—	718 000	839 000
M39×3	1 030	185 000	232 000	319 000	288 000	391 000	453 000	618 000	—	855 000	999 000

a P is the pitch of the thread.

b To calculate A_s see 8.2.

8 Test methods

8.1 Tensile test for machined test pieces

The following properties shall be checked on machined test pieces by tensile tests in accordance with ISO 6892.

- tensile strength, R_m ;
- lower yield stress, R_{eL} or stress at 0,2 % non-proportional elongation, $R_{p0,2}$;
- percentage elongation after fracture:

$$A = \frac{L_u - L_0}{L_0} \times 100 \%$$

- percentage reduction of area after fracture:

$$Z = \frac{S_0 - S_u}{S_0} \times 100 \%$$

The machined test piece shown in figure 1 shall be used for the tensile test. If it is not possible to determine the elongation after fracture due to the length of the bolt, the reduction of area after fracture shall be measured providing that L_o is at least $3 d_o$.

When machining the test piece, the reduction of the shank diameter of the heat-treated bolts and screws with $d > 16$ mm shall not exceed 25 % of the original diameter (about 44 % of the initial cross-sectional area) of the test piece.

Products in property classes 4.8, 5.8 and 6.8 (cold work-hardened products) shall be tensile tested full-size (see 8.2).

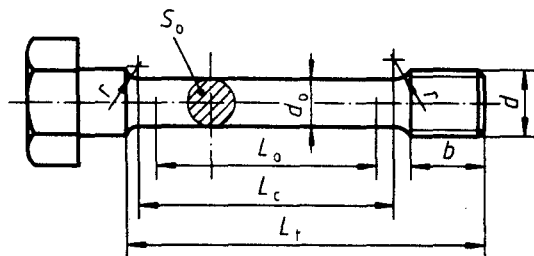

Key

d = nominal diameter

d_o = diameter of test piece ($d_o <$ minor diameter of thread)

b = threaded length ($b \geq d$)

$L_o = 5 d_o$ or $(5,65 \sqrt{S_o})$: original gauge length
for determination of elongation

$L_o \geq 3 d_o$: original gauge length

for determination of reduction of area

L_c = length of straight portion ($L_c + d_o$)

L_t = total length of test piece ($L_c + 2r + b$)

L_u = final gauge length (see ISO 6892:1998)

S_o = cross-sectional area before tensile test

S_u = cross-sectional area after fracture

r = fillet radius ($r \geq 4$ mm)

Figure 1 — Machined test piece for tensile testing

8.2 Tensile test for full-size bolts, screws and studs

The tensile test shall be carried out on full-size bolts in conformity with the tensile test on machined test pieces (see 8.1). It is carried out for the purpose of determining the tensile strength. The calculation of the tensile strength, R_{mT} , is based on the nominal stress area $A_{s, nom}$:

$$A_{s, nom} = \frac{\pi}{4} \left(\frac{d_2 + d_3}{2} \right)^2$$

where

d_2 is the basic pitch diameter of the thread (see ISO 724);

d_3 is the minor diameter of the thread

$$d_3 = d_1 - \frac{H}{6}$$

in which

d_1 is the basic minor diameter (see ISO 724);

H is the height of the fundamental triangle of the thread (see ISO 68-1).

For testing of full-size bolts, screws and studs the loads given in tables 6 to 9 shall be applied.

When carrying out the test, a minimum free threaded length equal to one diameter ($1d$) shall be subjected to the tensile load. In order to meet the requirements of this test, the fracture shall occur in the shank or the free threaded length of the bolt and not at the junction of the head and the shank.

The speed of testing, as determined with a free-running cross-head, shall not exceed 25 mm/min. The grips of the testing machine should be self-aligning to avoid side thrust on the test piece.

8.3 Torsional test

For the torsional test see ISO 898-7.

The test applies to bolts and screws with nominal thread diameters $d \leq 3$ mm as well as to short bolts and screws with nominal thread diameters $3 \text{ mm} \leq d \leq 10$ mm which cannot be subjected to a tensile test.

8.4 Hardness test

For routine inspection, hardness of bolts, screws and studs may be determined on the head, end or shank after removal of any plating or other coating and after suitable preparation of the test piece.

For all property classes, if the maximum hardness is exceeded, a retest shall be conducted at the mid-radius position, one diameter back from the end, at which position the maximum hardness specified shall not be exceeded. In case of doubt, the Vickers hardness test is decisive for acceptance.

Hardness readings for the surface hardness shall be taken on the ends or hexagon flats, which shall be prepared by minimal grinding or polishing to ensure reproducible readings and maintain the original properties of the surface layer of the material. The Vickers test HV 0,3 shall be the referee test for surface hardness testing.

Surface hardness readings taken at HV 0,3 shall be compared with a similar core hardness reading at HV 0,3 in order to make a realistic comparison and determine the relative increase which is permissible up to 30 Vickers points. An increase of more than 30 Vickers points indicates carburization.

For property classes 8.8 to 12.9 the difference between core hardness and surface hardness is decisive for judging of the carburization condition in the surface layer of the bolts, screws or studs.

There may not be a direct relationship between hardness and theoretical tensile strength. Maximum hardness values have been selected for reasons other than theoretical maximum strength consideration (e.g. to avoid embrittlement).

NOTE Careful differentiation should be made between an increase in hardness caused by carburization and that due to heat-treatment or cold working of the surface.

8.4.1 Vickers hardness test

The Vickers hardness test shall be carried out in accordance with ISO 6507-1.

8.4.2 Brinell hardness test

The Brinell hardness test shall be carried out in accordance with ISO 6506.

8.4.3 Rockwell hardness test

The Rockwell hardness test shall be carried out in accordance with ISO 6508.

8.5 Proof load test for full-size bolts and screws

The proof load test consists of two main operations, as follows:

- a) application of a specified tensile proof load (see figure 2);
- b) measurement of permanent extension, if any, caused by the proof load.

The proof load, as given in tables 7 and 9, shall be applied axially to the bolt in a tensile testing machine. The full proof load shall be held for 15 s. The length of free thread subjected to the load shall be one diameter ($1d$).

For screws threaded to the head, the length of free thread subjected to the load shall be as close as practical to one diameter ($1d$).

For measurement of permanent extension, the bolt or screw shall be suitably prepared at each end, see figure 2. Before and after the application of the proof load, the bolt or screw shall be placed in a bench-mounted measuring instrument fitted with spherical anvils. Gloves or tongs shall be used to minimize measurement error.

To meet the requirements of the proof load test, the length of the bolt, screw or stud after loading shall be the same as before loading within a tolerance of $\pm 12,5 \mu\text{m}$ allowed for measurement error.

The speed of testing, as determined with a free-running cross-head, shall not exceed 3 mm/min. The grips of the testing machine should be self-aligning to avoid side thrust on the test piece.

Some variables, such as straightness and thread alignment (plus measurement error), may result in apparent elongation of the fasteners when the proof load is initially applied. In such cases, the fasteners may be retested using a 3 % greater load, and may be considered satisfactory if the length after this loading is the same as before this loading (within the $12,5 \mu\text{m}$ tolerance for measurement error).

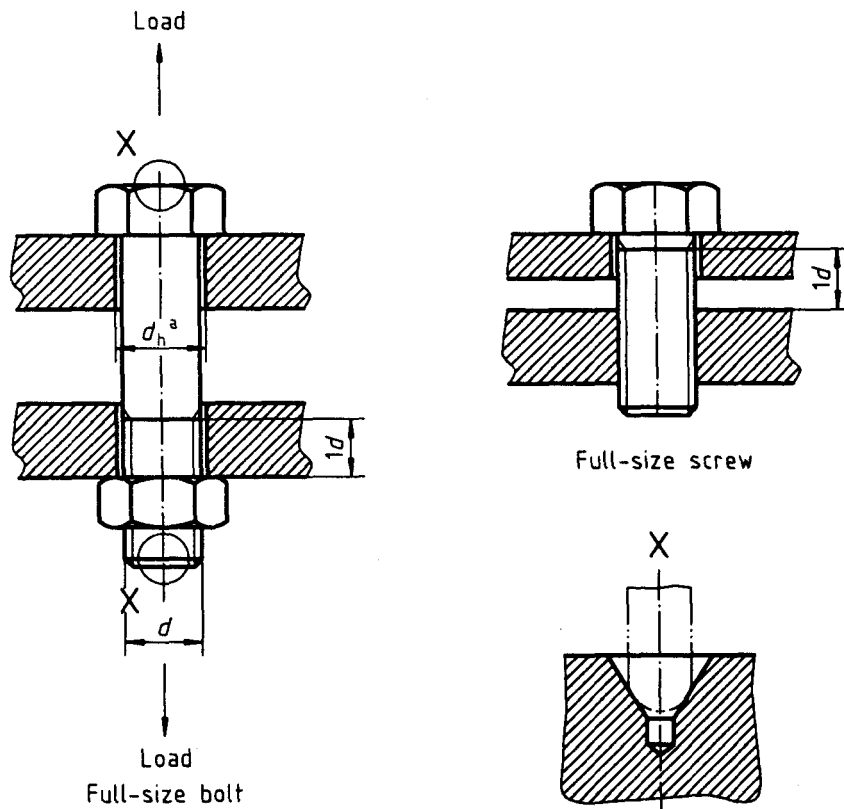

Required "sphere to cone" contact between the measuring points and the centre-drilled holes in the end of the bolt or screw.

^a d_h according to ISO 273, medium series (see table 10).

Figure 2 — Application of proof load to full-size bolts and screws

8.6 Test for tensile strength under wedge loading of full-size bolts and screws (not studs)

The wedge loading test shall not apply to countersunk head screws.

The test for strength under wedge loading shall be carried out in tensile testing equipment described in ISO 6892 using a wedge as illustrated in figure 3.

The minimum distance from the thread run-out of the bolt to the contact surface of the nut of the fastening device shall be d . A hardened wedge in accordance with tables 10 and 11 shall be placed under the head of the bolt or screw. A tensile test shall be continued until fracture occurs.

To meet the requirements of this test, the fracture shall occur in the shank or the free threaded length of the bolt, and not between the head and the shank. The bolt or screw shall meet the requirements for minimum tensile strength, either during wedge tensile testing or in a supplementary tensile test without a wedge, according to the values given for the relevant property class before fracture occurs.

Screws threaded to the head shall pass the requirement of this test if a fracture which causes failure originates in the free length of thread, even if it has extended or spread into the fillet area or the head before separation.

For product grade C, a radius r_1 should be used according to the formula

$$r_1 = r_{\max} + 0,2$$

in which

$$r_{\max} = \frac{d_{a \max} - d_{s \min}}{2}$$

where

r is the radius of curvature under head;

d_a is the transition diameter;

d_s is the diameter of unthreaded shank.

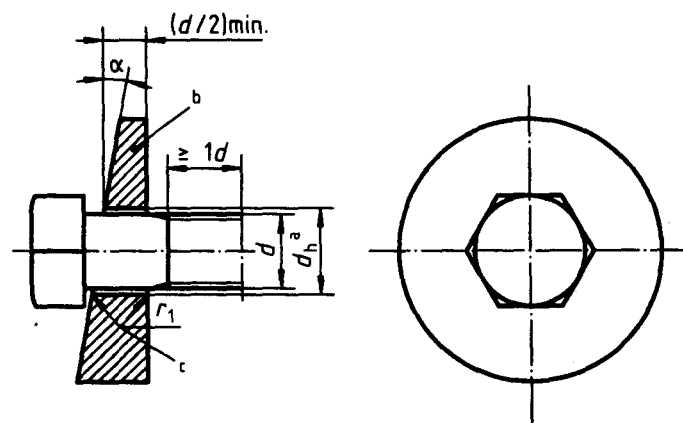

- a d_h according to ISO 273, medium series (see table 10).
- b Hardness: 45 HRC min.
- c Radius or chamfer of 45°.

Figure 3 — Wedge loading of full-size bolts

Table 10 — Hole diameters for wedge loading tensile test

Dimensions in millimetres

Nominal thread diameter d	d_h^a	r_1	Nominal thread diameter d	d_h^a	r_1
3	3,4	0,7	16	17,5	1,3
3,5	3,9	0,7	18	20	1,3
4	4,5	0,7	20	22	1,3
5	5,5	0,7	22	24	1,6
6	6,6	0,7	24	26	1,6
7	7,6	0,8	27	30	1,6
8	9	0,8	30	33	1,6
10	11	0,8	33	36	1,6
12	13,5	0,8	36	39	1,6
14	15,5	1,3	39	42	1,6

^a For square neck bolts, the hole shall be adapted to admit the square neck.

Table 11 — Wedge dimensions

Nominal diameter of bolt and screw d	Property classes for:			
	bolts with plain shank length $l_s \geq 2d$		screws threaded to the head and bolts with plain shank length $l_s < 2d$	
	3.6, 4.6, 4.8, 5.6	6.8, 12.9	3.6, 4.6, 4.8, 5.6	6.8, 12.9
	5.8, 8.8, 9.8, 10.9		5.8, 8.8, 9.8, 10.9	
mm	α $\pm 0^\circ 30'$			
$d \leq 20$	10°	6°	6°	4°
$20 < d \leq 39$	6°	4°	4°	4°

For products with head bearing diameters above $1,7d$ which fail the wedge tensile test, the head may be machined to $1,7d$ and re-tested on the wedge angle specified in table 11.

Moreover for products with head bearing diameters above $1,9d$, the 10° wedge angle may be reduced to 6° .

8.7 Impact test for machined test pieces

The impact test shall be carried out in accordance with ISO 83. The test piece shall be taken lengthwise, located as close to the surface of the bolt or screw as possible. The non-notched side of the test piece shall be located near the surface of the bolt. Only bolts of nominal thread diameters $d \geq 16$ mm can be tested.

8.8 Head soundness test for full-size bolts and screws with $d \leq 10$ mm and with lengths too short to permit wedge load testing

The head soundness test shall be carried out as illustrated in figure 4.

When struck several blows with a hammer, the head of the bolt or screw shall bend to an angle of $90^\circ - \beta$ without showing any sign of cracking at the shank head fillet, when viewed at a magnification of not less than $\times 8$ nor more than $\times 10$.

Where screws are threaded up to the head, the requirements may be considered met even if a crack should appear in the first thread, provided that the head does not snap off.

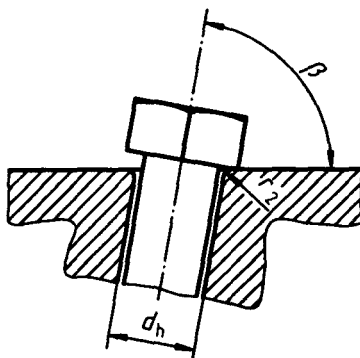

NOTE 1 For d_h and r_2 ($r_2 = r_1$), see table 10.

NOTE 2 The thickness of the test plate should be greater than $2d$.

Figure 4 — Head soundness test

Table 12 — Values of angle β

Property class	3.6	4.6	5.6	4.8	5.8	6.8	8.8	9.8	10.9	12.9
β	60°				80°					

8.9 Decarburization test: evaluation of surface carbon condition

Using the appropriate measuring method (8.9.2.1 or 8.9.2.2 as applicable), a longitudinal section of the thread shall be examined to determine whether the height of the zone of base metal (E) and the depth of the zone with complete decarburization (G), if any, are within specified limits (see figure 5).

The maximum value for G and the formulae for the minimum value for E are specified in table 3.

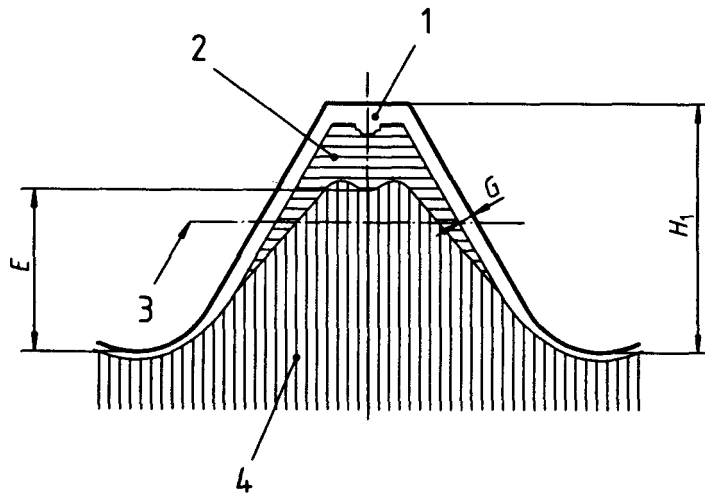

Key

- 1 Completely decarburized
- 2 Partially decarburized
- 3 Pitch line
- 4 Base metal

H_1 is the external thread height in the maximum material condition.

Figure 5 — Zones of decarburization

8.9.1 Definitions

8.9.1.1

base metal hardness

hardness closest to the surface (when traversing from core to outside diameter) just before an increase or decrease occurs denoting carburization or decarburization respectively

8.9.1.2

decarburization

generally, loss of carbon at the surface of commercial ferrous materials (steels)

8.9.1.3

partial decarburization

decarburization with loss of carbon sufficient to cause a lighter shade of tempered martensite and significantly lower hardness than that of the adjacent base metal without, however, showing ferrite grains under metallographic examination

8.9.1.4

complete decarburization

decarburization with sufficient carbon loss to show only clearly defined ferrite grains under metallographic examination

8.9.1.5

carburization

result of increasing surface carbon to a content above that of the base metal

8.9.2 Measurement methods

8.9.2.1 Microscopic method

This method allows the determination of E and G .

The specimens to be used are longitudinal sections taken through the thread axis approximately half a nominal diameter ($\frac{1}{2} d$) from the end of the bolt, screw or stud, after all heat-treatment operations have been performed on the product. The specimen shall be mounted for grinding and polishing in a clamp or, preferably, a plastic mount.

After mounting, grind and polish the surface in accordance with good metallographic practice.

Etching in a 3 % nital solution (concentrated nitric acid in ethanol) is usually suitable to show changes in microstructure caused by decarburization.

Unless otherwise agreed between the interested parties, a $\times 100$ magnification shall be used for examination.

If the microscope is of a type with a ground glass screen, the extent of decarburization can be measured directly with a scale. If an eyepiece is used for measurement, it should be of an appropriate type, containing a cross-hair or a scale.

8.9.2.2 Hardness method (Referee method for partial decarburization)

The hardness measurement method is applicable only for threads with pitches, $P \geq 1,25$ mm.

The Vickers hardness measurements are made at the three points shown on figure 6. Values for E are given in table 13. The load shall be 300 g.

The hardness determination for point 3 shall be made on the pitch line of the thread adjacent to the thread on which determinations at points 1 and 2 are made.

The Vickers hardness value at point 2 (HV_2) shall be equal to or greater than that at point 1 (HV_1) minus 30 Vickers units. In this case the height of the non-decarburized zone E shall be at least as specified in table 13.

The Vickers hardness value at point 3 (HV_3) shall be equal to or less than that at point 1 (HV_1) plus 30 Vickers units.

Complete decarburization up to the maximum specified in table 3 cannot be detected by the hardness measurement method.

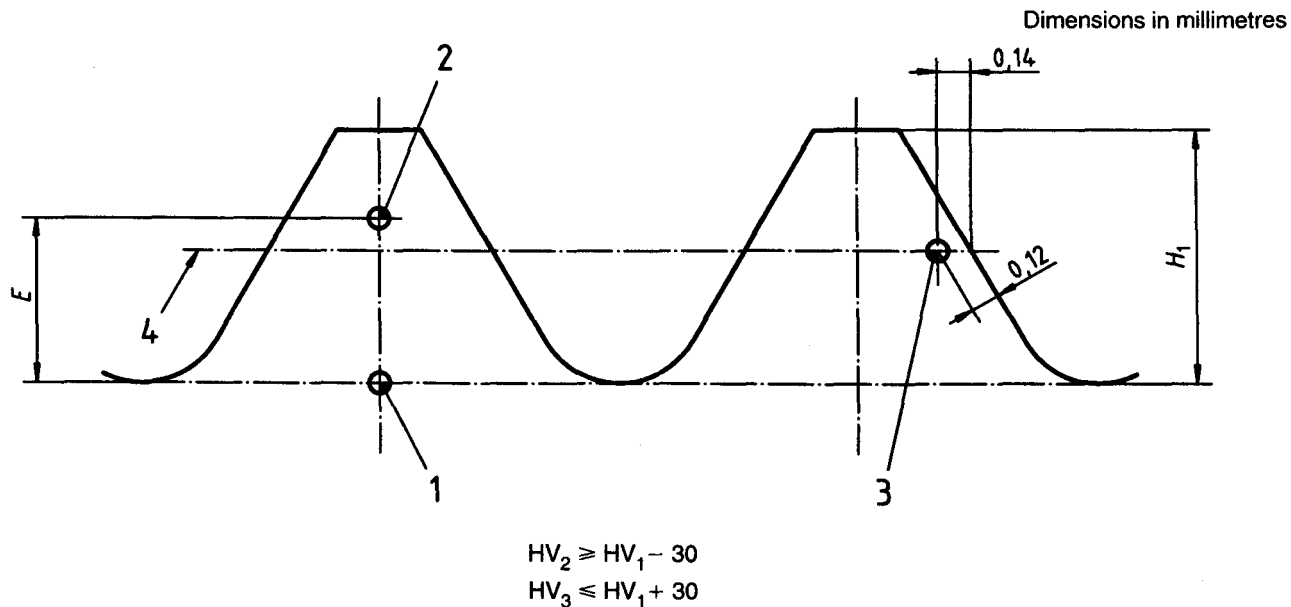

Key

- 1, 2, 3 Measurement points
- 4 Pitch line

Figure 6 — Hardness measurement for decarburization test

Table 13 — Values for H_1 and E

Pitch of the thread	P^a mm	0,5	0,6	0,7	0,8	1	1,25	1,5	1,75	2	2,5	3	3,5	4	
H_1 mm		0,307	0,368	0,429	0,491	0,613	0,767	0,920	1,074	1,227	1,534	1,840	2,147	2,454	
Property class	8.8, 9.8	E_{min}^b mm	0,154	0,184	0,215	0,245	0,307	0,384	0,460	0,537	0,614	0,767	0,920	1,074	1,227
	10.9		0,205	0,245	0,286	0,327	0,409	0,511	0,613	0,716	0,818	1,023	1,227	1,431	1,636
	12.9		0,230	0,276	0,322	0,368	0,460	0,575	0,690	0,806	0,920	1,151	1,380	1,610	1,841
<p>^a For $P \leq 1$ mm, microscopic method only.</p> <p>^b Calculated on the basis of the specification in 5.16, see table 3.</p>															

8.10 Retempering test

The mean of three core hardness readings on a bolt or screw, tested before and after retreating, shall not differ by more than 20 HV when retreating at a part temperature 10 °C less than the specified minimum tempering temperature and held for 30 min.

8.11 Surface discontinuity inspection

For the surface discontinuity inspection, see ISO 6157-1 or ISO 6157-3 as appropriate.

In the case of test programme A the surface discontinuity inspection is applied to test bolts before machining.

9 Marking

Mechanical fasteners manufactured to the requirements of this International Standard shall be marked in accordance with the provisions of 9.1 to 9.5.

Only if all requirements in this part of ISO 898 are met, shall parts be marked and/or described according to the designation system described in clause 3.

Unless otherwise specified in the product standard, the height of embossed markings on the top of the head shall not be included in the head height dimensions.

Marking of slotted and cross recessed screws is not usual.

9.1 Manufacturer's identification marking

A manufacturer's identification mark shall be included during the manufacturing process, on all products which are marked with property classes. Manufacturer's identification marking is also recommended on products which are not marked with property class.

For the purposes of this part of ISO 898 a distributor marking fasteners with his unique identification mark shall be considered a manufacturer.

9.2 Marking symbols for property class

Marking symbols are shown in table 14.

Table 14 — Marking symbols

Property class	3.6	4.6	4.8	5.6	5.8	6.8	8.8	9.8	10.9	10.9	12.9
Marking symbol ^{a,b}	3.6	4.6	4.8	5.6	5.8	6.8	8.8	9.8	10.9	10.9 ^b	12.9

^a The full-stop in the marking symbol may be omitted.
^b When low carbon martensitic steels are used for property class 10.9 (see table 2).

In the case of small screws or when the shape of the head does not allow the marking as given in table 14 the clock face marking symbols as given in table 15 may be used.

Table 15 — Clock-face system for marking bolts and screws

Marking symbols	Property class					
	3.6	4.6	4.8	5.6	5.8	
	Property class					
	6.8	8.8	9.8	10.9	10.9	12.9

^a The twelve o'clock position (reference mark) shall be marked either by the manufacturer's identification mark or by a point.
^b The property class is marked by a dash or a double dash and in the case of 12.9 by a point.

9.3 Identification

9.3.1 Hexagon and hexalobular head bolts and screws

Hexagon and hexalobular head bolts and screws (including products with flange) shall be marked with the manufacturer's identification mark and with the marking symbol of the property class given in table 14.

The marking is obligatory for all property classes, preferably on the top of the head by indenting or embossing or on the side of the head by indenting (see figure 7). In the case of bolts or screws with flange, marking shall be on the flange where the manufacturing process does not allow marking on the top of the head.

Marking is required for hexagon and hexalobular head bolts and screws with nominal diameters $d \geq 5$ mm.

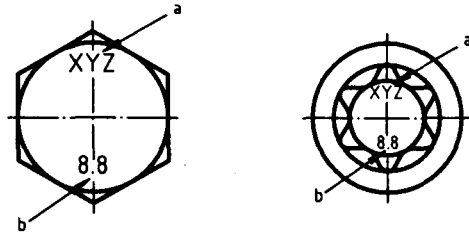

- a Manufacturer's identification mark
- b Property class

Figure 7 — Examples of marking on hexagon and hexalobular head bolts and screws

9.3.2 Hexagon and hexalobular socket head cap screws

Hexagon and hexalobular socket head cap screws shall be marked with the manufacturer's identification mark and with the marking symbol of the property class given in table 14.

The marking is obligatory for property classes 8.8 and higher, preferably on the side of the head by indenting or on the top of the head by indenting or embossing (see figure 8).

Marking is required for hexagon and hexalobular socket head cap screws with nominal diameters $d \geq 5$ mm.

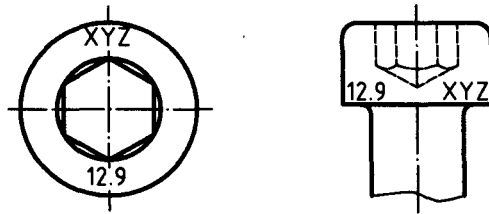

Figure 8 — Examples of marking on hexagon socket head cap screws

9.3.3 Cup head square neck bolts

Cup head square neck bolts with property classes 8.8 and higher shall be marked with the manufacturer's identification mark and with the marking symbol of the property class as given in table 14.

The marking is mandatory for bolts with nominal diameters $d \geq 5$ mm. It shall be on the head by indenting or embossing (see Figure 9).

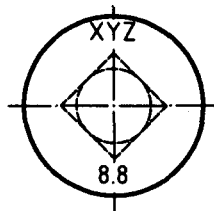

Figure 9 — Example of marking cup head square neck bolts

9.3.4 Studs

Studs with nominal thread diameters $d \geq 5$ mm, of property class 5.6 and property classes 8.8 and higher shall be marked by indenting with the marking symbol of the property class as given in table 14 and the manufacturer's identification mark on the unthreaded part of the stud (see Figure 10).

If marking on the unthreaded part is not possible, marking of property class only on the nut end of the stud is allowed, see figure 10. For studs with interference fit, the marking shall be at the nut end with manufacturer's identification marking only if it is possible.

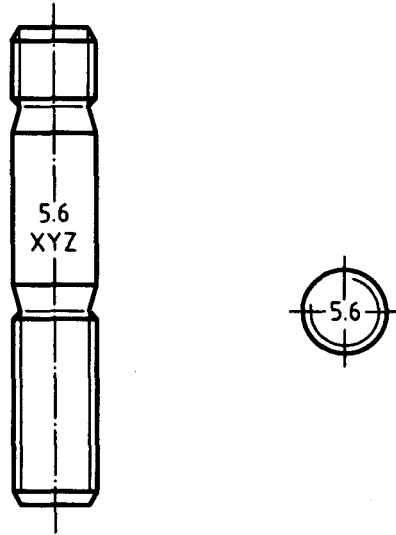

Figure 10 — Marking of studs

The symbols in table 16 are permissible as an alternative identification of property classes.

Table 16 — Alternative marking symbols for studs

Property class	5.6	8.8	9.8	10.9	12.9
Marking symbol	—	○	+	□	△

9.3.5 Other types of bolts and screws

If agreed between the interested parties, the same marking systems as described in the previous paragraphs of clause 9 shall be used for other types of bolts and screws and for special products.

9.4 Marking of bolts and screws with left-hand thread

Bolts and screws with a left-hand thread shall be marked with the symbol shown in figure 11, either on the top of the head or on the point.

Marking is required for bolts and screws with nominal thread diameters $d \geq 5$ mm.

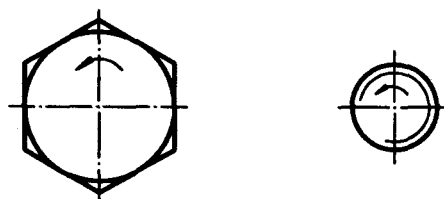
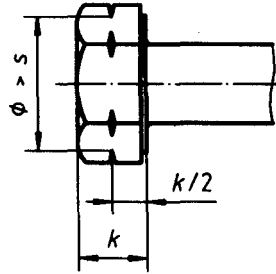

Figure 11 — Left-hand thread marking

Alternative marking for left-hand thread as shown in figure 12 may be used for hexagon bolts and screws.



Key

- s is the width across flats
- k is the height of the head

Figure 12 — Alternative left-hand thread marking

9.5 Alternative marking

Alternative or optional permitted marking as stated in 9.2 to 9.4 should be left to the choice of the manufacturer.

9.6 Marking of packages

Marking with manufacturer's identification and property class is mandatory on all packages for all sizes.

Annex A
 (informative)

Lower yield stress or stress at 0,2 % non-proportional elongation at elevated temperature

The mechanical properties of bolts, screws and studs will vary in a variety of ways with increasing temperature. Table A.1, which is for guidance only, is an approximate representation of the reduction in lower yield stress or 0,2 % non-proportional elongation which may be experienced at a variety of elevated temperatures. These data shall not be used as a test requirement.

Table A.1 — Lower yield stress or stress at 0,2 % non-proportional elongation at elevated temperature

Property class	Temperature °C				
	+ 20	+ 100	+ 200	+ 250	+ 300
	Lower yield stress, R_{eL} or stress at 0,2 % non-proportional elongation $R_{p0,2}$ N/mm ²				
5.6	300	270	230	215	195
8.8	640	590	540	510	480
10.9	940	875	790	745	705
10.9	940	—	—	—	—
12.9	1 100	1 020	925	875	825

Continuous operating at elevated service temperature may result in significant stress relaxation. Typically 100 h service at 300 °C will result in a permanent reduction in excess of 25 % of the initial clamping load in the bolt due to decrease in yield stress.

Bureau of Indian Standards

BIS is a statutory institution established under the *Bureau of Indian Standards Act, 1986* to promote harmonious development of the activities of standardization, marking and quality certification of goods and attending to connected matters in the country.

Copyright

BIS has the copyright of all its publications. No part of these publications may be reproduced in any form without the prior permission in writing of BIS. This does not preclude the free use, in the course of implementing the standard, of necessary details, such as symbols and sizes, type or grade designations. Enquiries relating to copyright be addressed to the Director (Publications), BIS.

Review of Indian Standards

Amendments are issued to standards as the need arises on the basis of comments. Standards are also reviewed periodically; a standard along with amendments is reaffirmed when such review indicates that no changes are needed; if the review indicates that changes are needed, it is taken up for revision. Users of Indian Standards should ascertain that they are in possession of the latest amendments or edition by referring to the latest issue of 'BIS Catalogue' and 'Standards : Monthly Additions'.

This Indian Standard has been developed from Doc : No. BP 33 (0118).

Amendments Issued Since Publication

Amend No.	Date of Issue	Text Affected

BUREAU OF INDIAN STANDARDS

Headquarters:

Manak Bhavan, 9 Bahadur Shah Zafar Marg, New Delhi 110 002
Telephones : 323 01 31, 323 33 75, 323 94 02

Telegrams: Manaksanstha
(Common to all offices)

Regional Offices :

Central : Manak Bhavan, 9 Bahadur Shah Zafar Marg
NEW DELHI 110 002

Telephone

{ 323 76 17
{ 323 38 41

Eastern : 1/14 C. I. T. Scheme VII M, V. I. P. Road, Kankurgachi
KOLKATA 700 054

{ 337 84 99, 337 85 61
{ 337 86 26, 337 91 20

Northern : SCO 335-336, Sector 34-A, CHANDIGARH 160 022

{ 60 38 43
{ 60 20 25

Southern : C. I. T. Campus, IV Cross Road, CHENNAI 600 113

{ 254 12 16, 254 14 42
{ 254 25 19, 254 13 15

Western : Manakalaya, E9 MIDC, Marol, Andheri (East)
MUMBAI 400 093

{ 832 92 95, 832 78 58
{ 832 78 91, 832 78 92

Branches : AHMADABAD. BANGALORE. BHOPAL. BHUBANESHWAR. COIMBATORE.
FARIDABAD. GHAZIABAD. GUWAHATI. HYDERABAD. JAIPUR. KANPUR.
LUCKNOW. NAGPUR. NALAGARH. PATNA. PUNE. RAJKOT. THIRUVANANTHAPURAM.